

3 TECHNICAL BACKGROUND

3.1 What is fieldbus technology?

Fieldbus technology is used for data transmission between sensors / actuators and automation devices, e.g. programmable logic controllers or process control systems. Conventional on-site terminal boxes are increasingly being replaced by Remote I/O systems.

A fieldbus system has the following functionalities:

- Data transport from the connected field devices to the control center level and vice-versa
- Error analysis between interfaces
- Network monitoring
- Transfer of data regarding the current network status to the control center level

3.1.1 Principles

The term fieldbus stands for various physical transmission devices, e.g. RS 485, fibre-optic cables, etc., as well as for various digital protocols, e.g. Profibus, Modbus, ControlNet, etc. These protocols can be used to transfer the data between the sensors / actuators and the automation devices.

A fieldbus can be used as:

- Purely digital
- For distances of several 100 m to several km
- At speeds of between 31.25 kbit/s and 10 Mbit/s
- For several "users", e.g. field devices or field stations (in contrast to a purely point-to-point-connection)
- For transmission of several 10's to several 100's of signals
- Also in hazardous locations, e.g. with the degree of protection: "intrinsic safety"

3.2 How does a fieldbus system function?

The diagram displays the structure of information processing in a fieldbus system:

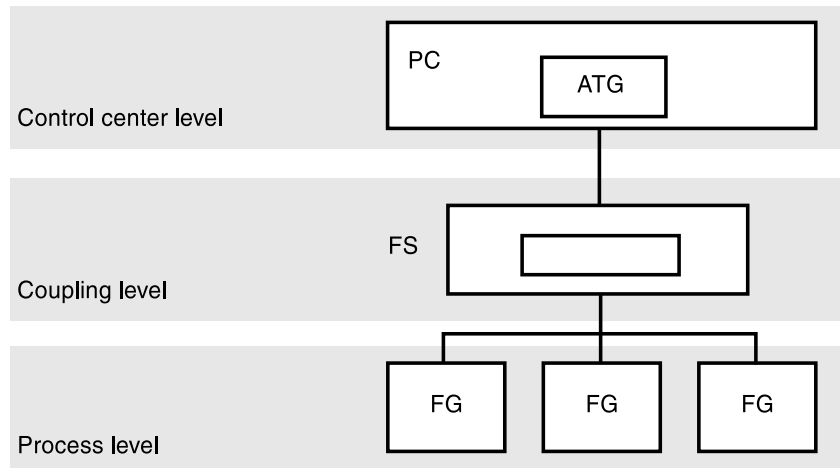

Fig. 3-1 Structure of a fieldbus system

ATG Automation devices (PLS, SPS, PC)

FS Field station

FG Field devices (sensors and actuators)

Control center level

At the control center level, programmable logic controllers, process control systems or PC's control and regulate the process to be automated. They collect the input signals from the sensors (inputs), process the signals and generate output signals to the actuators (outputs). In addition, diagnostic information is collected and evaluated from the process level.

Coupling level

At the coupling level, signal conditioning is generally carried out. In the simplest case, bus-capable field devices are, e.g., directly connected with a terminal box to the fieldbus. Non-bus capable conventional field devices are adapted to the fieldbus by means of a field station. The installation of the field station generally occurs at process level, but can also occur in the control room.

Process level

The process level includes the field devices, sensors and actuators. They collect information from the process or influence the process. Field devices send or receive signals via the field stations to/from the control center level.

3.3 Where are fieldbus systems used?

Fieldbuses are used in all areas of factory automation and in process technical industries. A relatively new application for fieldbuses is in those industries that contain hazardous locations.

Application areas include:

- Chemical industry
- Petrochemical industry
- Offshore technology
- Pharmaceutical industry

3.4 What is a Remote I/O system for Ex areas?

Until now, for applications in hazardous locations, the "coupling level" was generally installed close to the control center level, in the control room. The coupling level in this case consists of the Ex i isolators and marshalling box. When the input and output components of the automation devices are combined with the Ex i isolators and can be installed within the process, this is known as a Remote I/O system.

3.4.1 Advantages of Remote I/O systems

- Simple** The removal of Ex i isolators and marshalling box, together with the replacement of wiring between field devices and automation devices by the fieldbus, results in a considerable simplification of planning, installation, commissioning and servicing. Remote I/O systems for the Ex area can now be installed as easily as normal industrial I/O systems.
- Flexible** A system concept for installation in Ex areas (Zone 2, Zone 1, Class 1 Division 2 and Class 1 Division 1) and in non-Ex areas. Additional modules can be inserted during operation. It is also possible to connect non-Ex signals. HART field devices can be fully integrated in the I.S. 1 system.
- Economic** Modules available with 4, 8 or 16 channels. Supports are not required. They are mounted directly on a 35 mm DIN rail, which is then inserted in the BusRail. Power supply to the I/O modules of a field station from a CPU & Power Module.
- Safe** Scaleable redundancy of cables, fieldbus connections, power supply and internal system buses. Optimized data transfer on the internal system bus for extremely rapid reaction times. Functions adjustable via parameters.

3.5 Which protocols can be used?

Various communication protocols can be used with the Remote I/O systems. These include, for instance:

- Fieldbus DP
- Specially developed buses (example: internal bus from R. STAHL)
- ServiceBus
- HART protocol



Each group of communication protocols may include sub-groups. For example, the fieldbus DP supports the communication protocols Profibus and Modbus.

3.5.1 Differences between protocols

The protocols differ in:

- Type of application
- Speed
- Overlay options of digital or analog signals at the higher levels of the communication layer
- Intrinsic safety
- Conformity to standards

OPERATING INSTRUCTIONS FOR THE I.S. 1 SYSTEM
