



Operating Instructions

Circuit breakers for motor protection

> 8527/2



1 Contents

1	Contents	2
2	General Information	2
3	General Safety Information	3
4	Designated Use	4
5	Technical Data	5
6	Transport, Storage and Disposal	8
7	Assembly	8
8	Installation	9
9	Commissioning	11
10	Maintenance	12
11	Accessories and Spare Parts	13
12	Type Examination Certificate (Page 1)	14
13	Declaration of Conformity	15
14	Tripping Characteristic Curves	16

2 General Information

2.1 Manufacturer

R. STAHL Schaltgeräte GmbH
Am Bahnhof 30
D-74638 Waldenburg

Phone: +49 7942 943-0
Fax: +49 7942 943-4333
Internet: www.stahl.de

2.2 Information Regarding the Operating Instructions

ID NO.: 8527602300
Publication Code: S-BA-8527/2-01-en-10/10/2007

We reserve the right to make technical changes without notice.

3 General Safety Information

3.1 Safety Instructions for Assembly and Operating Personnel

The operating instructions contain basic safety instructions which are to be observed during installation, operation and maintenance. Non-observance will endanger persons, plant and the environment.

⚠ WARNING

Risk due to unauthorised work being performed on the device!

- ▷ Risk of injury and damage to equipment.
- ▶ Mounting, installation, commissioning and servicing work must only be performed by personnel who are both authorised and suitably trained for this purpose.

Before assembly/commissioning:

- ▶ Read through the operating instructions.
- ▶ Give adequate training to the assembly and operating personnel.
- ▶ Ensure that the contents of the operating instructions are fully understood by the personnel in charge.
- ▶ The national installation and assembly regulations (e.g. IEC/EN 60079-14) apply.

If you have questions:

- ▶ Contact the manufacturer.

When operating the device:

- ▶ Ensure the operating instructions are made available on location at all times.
- ▶ Observe safety instructions.
- ▶ Observe national safety and accident prevention regulations.
- ▶ Only run the device according to its performance data.
- ▶ Servicing/maintenance work or repairs which are not described in the operating instructions must not be performed without prior agreement with the manufacturer.
- ▶ Any damage may render explosion protection null and void.
- ▶ No changes to the device impairing their explosion protection are permitted.
- ▶ Install and use the device only if it is undamaged, dry and clean.

3.2 Warnings

Warnings are sub-divided in these operating instructions according to the following scheme:







⚠ WARNING

Type and source of the danger!

- ▷ Possible consequences.
- ▶ Measures for avoiding the danger.

They are always identified by the signalling word "WARNING" and sometimes also have a symbol which is specific to the danger involved.

3.3 Symbols Used

	Action request: Describes actions to be carried out by the user.
	Reaction sign: Describes results i.e. reactions on activities.
	Bullet
	Sentinel: Describes the notes and recommendations.
	Warning sign: Danger from energised parts!
	Warning sign: Danger due to an explosive atmosphere!

3.4 Conformity to standards

The device complies with the following regulations and standards:

- ✗ Directive 94/9/EC
- ✗ EN 50014, EN 50018, EN 50019
- ✗ IEC/EN 60947-1, IEC/EN 60947-2, IEC/EN 60947-4, IEC/EN 60947-5

4 Designated Use

The motor protection circuit breaker of series 8527 is used in explosion-protected areas to protect and switch EEx e and EEx d motors and to protect systems.

The devices are approved for use in hazardous areas of zones 1, 2, 21 and 22.

The temperature class applicable depends on where the enclosure is installed.

Change the circuit-breaker at the end of its operating life (see technical data).

Special characteristics of the motor protection circuit breaker:

- ✗ Phase failure sensitivity according to IEC/EN 60947.
- ✗ Temperature compensation within ambient temperature range.
- ✗ Trip-free release.
- ✗ Isolator characteristics.
- ✗ Master switch and EMERGENCY-STOP characteristics via appropriate ancillary device.
- ✗ Can be fitted in any position.
- ✗ Switch actuator can be triple-locked in Off position by cylinder lock (see Accessories).

WARNING

Only use the device for its intended purpose!

- ▷ Otherwise, the manufacturer's liability and warranty expire.
- ▷ Only use the device under the operating conditions described in the operating instructions.
- ▷ The device must only be used in areas subject to explosion hazards according to these operating instructions.

5 Technical Data

Explosion protection				
Gas explosion protection	⊕ II 2 G EEx de IIC T.			
	Type	Adjustment range	Temperature class	T _{max.}
	8527/21	0.1 A up to 0.25 A	T6	80 °C
	8527/22	0.25 A up to 12.5 A 12.5 A up to 16 A	T5 T4	95 °C 130 °C
	8527/23	0.1 A up to 12.5 A	T6	80 °C
	8527/24	16 A up to 22.5 A	T5	95 °C
Dust explosion protection	⊕ II 2 D IP 65 T80 °C, T95 °C, T130 °C			
Certificates				
Gas explosion protection	DMT 02 ATEX E 026			
Dust explosion protection	LCIE 02 ATEX 6241 (see type 8146/5)			
Housing material	Polyester resin, glass fibre reinforced, dark grey, similar to RAL 7024, Surface resistance ≤ 10 ⁹ ohms; impact strength ≥ 7 Nm, Material self-extinguishing and flame resistant according to IEC-92-1, UL 94, ASTM D 635-77			
Mounting position	any			
Ingress protection	IP 66			
Switch element				
Main contacts	3-pole			
Rated operational voltage	max. 690 V, AC, 50 Hz / 60 Hz			
Rated operational current	0.1 A ... 22.5 A			
Switching capacity	according to the selected adjustment range (AC)			
	230 V	400 V	500 V	690 V
	6.4 kW	11.4 kW	14.4 kW	20.0 kW
Thermal overcurrent trip	according to the adjustment range of the switch, selectable on the switch see tripping characteristic curve			
Electromagnetic fast trip	Adjustment range	Threshold values set at factory		
	0.16 A ... 0.63 A	7.5 ... 12.0 I _n		
	1.0 A ... 2.5 A	9.0 ... 14.0 I _n		
	4.0 A ... 6.3 A	10.0 ... 15.0 I _n		
	9.0 A ... 25.0 A	12.5 ... 17.5 I _n		

Short circuit protection	Adjustment range from ... to	Highest rated current of the short circuit fuse if $I_{CC} > I_{CS}$									
		at 230 V AC		at 400 V AC		at 440 V AC		at 500 V AC		at 690 V AC	
		I_{CS}	g_L , aM	I_{CS}	g_L , aM	I_{CS}	g_L , aM	I_{CS}	g_L , aM	I_{CS}	g_L , aM
	0.1 A ... 0.16 A to 1.0 A ... 1.6 A	short-circuit proof, no fuse needed up to $I_{CC} = 100$ kA									
	1.6 A ... 2.5 A								40 kA	25 A	
	2.5 A ... 4.0 A						60 kA	35 A / 40 A	10 kA	40 A	
	4.0 A ... 6.3 A				70 kA	50 A	40 kA	50 A	7 kA	40 A	
	6.3 A ... 9.0 A				50 kA	80 A	30 kA	80 A	5 kA	50 A	
	9.0 A ... 12.5 A		75 kA	80 A	45 kA	80 A	27 kA	80 A	4.5 kA	50 A	
	12.5 A ... 16.0 A		60 kA	100 A	40 kA	100 A	25 kA	100 A	4 kA	50 A	
	16.0 A ... 20.0 A		55 kA	100 A	35 kA	100 A	22 kA	100 A	3.5 kA	50 A	
	20.0 A ... 25.0 A		50 kA	125 A	30 kA	125 A	20 kA	125 A	3 kA	50 A	
		I_{CS} = Breaking capacity of rated operating short circuit I_{CC} = Projected short circuit current at the installation location									
mechanical		10 ⁵ operations									
Ambient temperature		- 20 °C ... + 40 °C - 40 °C ≤ Ta ≤ 55 °C									
Operating handle		Labelling: 0 - I; can be padlocked in 3 positions in 0-position Colour: Standard: Handle black, protective collar black Special version: Handle red, collar yellow (for Emergency Stop)									
Accessories		Option: None; 1 NC + 1 NO; 2 NC + 2 NO									
Auxiliary contacts		max. 500 V, AC									
Rated operational voltage		AC 15: 24 V / 2.5 A 230 V / 2 A 400 V / 1 A DC 13: 24 V / 2.5 A 60 V / 2.5 A 110 V / 0.6 A 220 V / 0.25 A 440 V / - A									
Undervoltage trip		When power is lost, circuit-breaker trips; this prevents unwanted restarting, e.g. of a motor									
Function		≥ 0.85 × U _c									
Pick-up voltage		0,7 ... 0.35 × U _c									
Drop-out											
Power input		0.9 VA									
Inrush		0.9 VA									
Holding											
Voltage trip		For remote tripping of circuit-breakers by applying actuating voltage									
Function		≥ 0.85 × U _c									
Pick-up voltage		Switches off automatically via integrated contact switch									
Relative duty cycle		24 - 60 V: 14.4 - 90 VA; 110 - 240 V: 13 - 61 VA; 220 - 415 V: 17.6 - 62.3 VA									
Power input		Switches off automatically via integrated contact switch									
Inrush											
Holding											
Ammeter		Type 8405; dimensions 64 mm x 64 mm									
Version		Moving iron: class 2.5; direct measuring; overload scale 1:2									
Movement		according to the adjustment range of the switch									
Measuring range		2 × I _e 25 s; 50 × I _e 1 s									
Overload capacity											

Cable entries

Standard

Type	Accessories 1)	8161 Cable glands		8290 Stopping plugs
		M25 x 1.5	M32 x 1.5	M25 x 1.5
8527/21	without	2	-	1
	with	3	-	-
8527/22	without	2	-	1
	with	3	-	-
8527/23; 8527/24	without	-	2	1
	with	1	2	-
8527/25; 8527/26	without	2	-	1
	with	3	-	-
0.1 A ... 12.5 A	without	-	2	1
12.5 A ... 22.5 A	with	1	2	-

M 25 x 1.5 for cables \varnothing 12 mm ... 17 mm

M 32 x 1.5 for cables \varnothing 10 mm ... 18 mm

Special

Connection

1) Accessories: Auxiliary contacts, undervoltage trip, voltage trip on request

8527/21	directly to fitted components		
8527/22	Main contacts	1.5 mm ² ... 6 mm ² finely stranded wire 1.5 mm ² ... 10 mm ² single-wire	
	Auxiliary contacts	0.75 mm ² ... 1.5 mm ² finely stranded wire 0.75 mm ² ... 2.5 mm ² single-wire	
8527/23 8527/24 8527/25 8527/26	on terminals	0.5 mm ² ... 6 mm ² finely stranded wire 0.5 mm ² ... 10 mm ² single-wire	

Please note:

Compare cable diameter with cable diameter range of cable entries

Dimensional drawings (all dimensions in mm) - subject to alterations

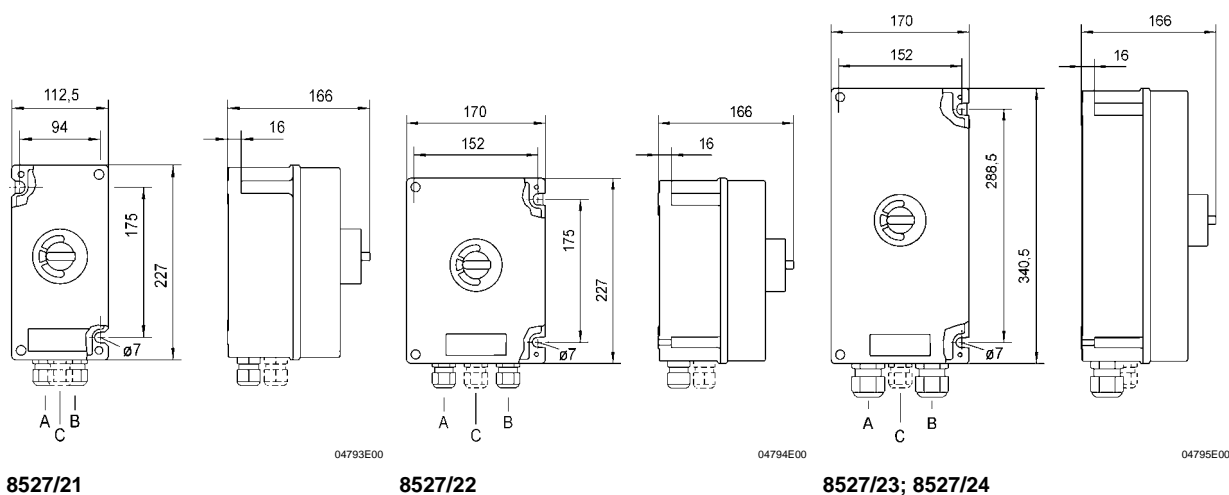

Dimensional drawings (all dimensions in mm) - subject to alterations

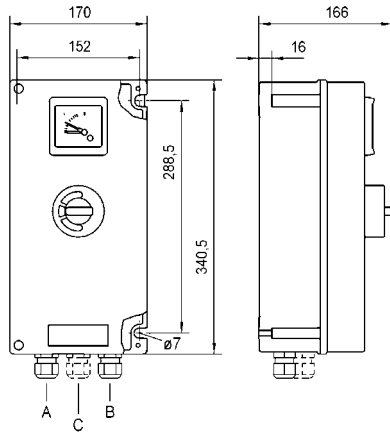

04796E00

8527/25; 8527/26

Cable entries

Type	Accessories	Cable glands 8161		Stopping plugs 8290
		M25 x 1.5	M32 x 1.5	M25 x 1.5
8527/21	without	A + B	--	C
	with	A, B, C	--	--
8527/22	without	A + B	--	C
	with	A, B, C	--	--
8527/23; 8527/24	without	--	A + B	C
	with	C	A + B	--
8527/25; 8527/26 0.1 A ... 12.5 A	without	A + B	--	C
	with	A, B, C	--	--
12.5 A ... 22.5 A	without	--	A + B	C
	with	C	A + B	--

6 Transport, Storage and Disposal

Transport

- ▶ Shock-free in its original carton, do not drop, handle carefully.

Storage

- ▶ Store in a dry place in its original packaging

Disposal



- ▶ Ensure environmentally friendly disposal of all components according to legal regulations.

7 Assembly

	Install a protective roof or wall if the explosion-protected electrical device is mounted outdoors.
	Drilling template see dimensional drawing

8 Installation

8.1 Mains Connection

 WARNING	
	<p>Incorrectly installed components!</p> <ul style="list-style-type: none"> ▶ Explosion protection cannot be guaranteed any more if the components are incorrectly installed. ▶ Carry out the installation in strict accordance with the instructions and national safety and accident prevention regulations (e.g. EN 60079-14).

- ▶ In case of a rated operational current of > 15.5 A, a direct connection is **only** permitted with heat-resistant cables!
- ▶ Be especially careful when connecting the cable.
- ▶ The conductor insulation must reach to the terminal.
- ▶ The conductor itself must not be damaged when removing the insulation.
- ▶ Select the cables and the mode of running them in a way that the maximum permitted cable temperature is not exceeded.

Circuit diagram of the device with designations of the connections and options a), b), c) or d) and connections.

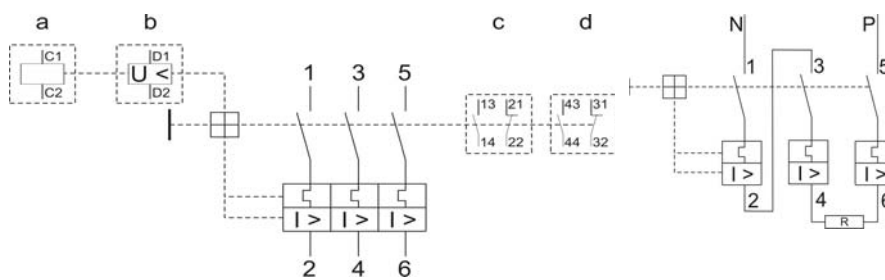

Three-phase alternating current

Single-phase alternating current and direct current

Options:

a) = Voltage trip

b) = Undervoltage trip

c) = Additional auxiliary contact



d) = Additional auxiliary contact

L1(1), L2(3), L3(5) = phase (input)







T1(2), T2(4), T3(6) = phase (output)

N = neutral

8.2 Cross sections of the rated connections

 WARNING	
	<p>Incorrectly installed components!</p> <ul style="list-style-type: none"> ▷ Explosion protection cannot be guaranteed any more if the components are incorrectly installed. ▶ If end covering sleeves are used, they have to be gas-tight and fitted using a suitable tool. ▶ Always connect the earth lead.

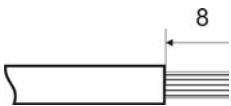
- X One or two conductors can be fitted to one connection terminal.
- X In case of single-wired conductors, both conductors must have the same cross section and be of the same material.
- X The conductors can be connected without previous measures.

	Main contact terminals	Auxiliary contact terminals	Terminal blocks
	 11532E00	 11533E00	 11533E00
single-wire	2 x 1.5 ... 10 mm ² 2 x AWG 16 to 8	2 x 0.75 ... 1.5 mm ² 2 x AWG 18 to 13	1 x 0.5 ... 10 mm ² 1 x AWG 20 to 8
	 11534E00	 11535E00	 11535E00
single-wire or stranded	2 x 1.5 ... 6 mm ² 2 x AWG 16 to 10	2 x 0.75 ... 1.5 mm ² 2 x AWG 18 to 16	1 x 0.5 ... 6 mm ² 2 x AWG 20 to 10
Permitted torques	1.8 ... 2.0 Nm	1 ... 1.2 Nm	1.5 ... 1.8 Nm

8.3 Back-Up Fuses for Devices with Ammeter

	In case of devices with integrated ammeter, select the back-up fuse in a way that a value 50 times higher of the rated current of the ammeter will not be exceeded.
---	---

8.4 Back-Up Fuses for Auxiliary Circuits

- ▶ Basically, auxiliary circuits must be short-circuit protected using 10 A gL.

Exception:

- ▶ The undervoltage trip is directly connected to the main contact terminals of the motor protection circuit breaker.
- ▷ A protection is not necessary.
- ▶ Realise the connection with special jumpers (see accessories).

Device types
8527/22, 8527/24, 8527/26

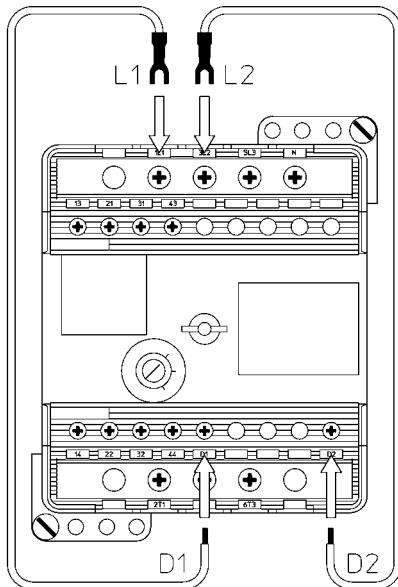

09140E00

Device types
8527/21, 8527/23, 8527/25

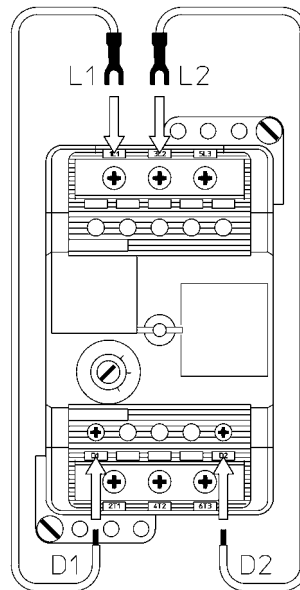

09029E00

9 Commissioning

Before commissioning

- ▶ Check that cables and lines are clamped properly.
- ▶ Inspect cable glands for damage.
- ▶ Control torques.
- ▶ Ensure that the connection has been correctly made.
- ▶ Ensure that unused cable entries are sealed with plugs certified to Directive 94/9/EC.
- ▶ Ensure that unused holes are sealed by stopping plugs certified to Directive 94/9/EC.
- ▶ Ensure that all screws and nuts are fully tightened.
- ▶ Ensure that the device contains no foreign bodies.
- ▶ Adjust the rated operational current on the motor protection circuit breaker.

9.1 Setting the Thermal Overcurrent Trip

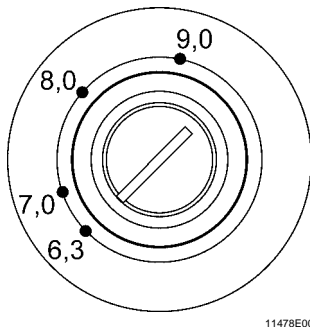

The required current can be adjusted using a suitable screwdriver.
The open end of the slot indicates the selected current (see drawing for an example: rated current 6.3 A).

	<p>If ambient temperatures differ from standard values, or if the ambient temperatures of motor and circuit breaker are different, the trip response must be checked and the current changed if necessary.</p>
--	--

10 Maintenance

⚠ WARNING	
<p>Risk due to unauthorised work being performed on the device!</p> <ul style="list-style-type: none"> ▷ Risk of injury and damage to equipment. ▶ Mounting, installation, commissioning and servicing work must only be performed by personnel who are both authorised and suitably trained for this purpose. 	
⚠ WARNING	
	<p>Danger from energised parts!</p> <ul style="list-style-type: none"> ▷ Risk of severe injuries. ▶ All connections and wiring must be disconnected from the power supply. ▶ Secure the connections against unauthorised activation.
⚠ WARNING	
	<p>Short circuit in the circuit</p> <ul style="list-style-type: none"> ▷ After multiple short circuits, the flameproof encapsulation is no longer guaranteed. ▶ After a short circuit, check the functionality of the device. ▶ Replace the entire device if needed.

10.1 Regular Maintenance Work

- ▶ Consult the relevant regulations (e.g. IEC/EN 60079-17) to determine the type and extent of inspections.
- ▶ Plan the intervals so that any defects in the equipment which may be anticipated are promptly detected.

To check as part of the servicing/maintenance schedule:

- ✗ Check that cables and lines are clamped properly.
- ✗ Inspect device for visible damage.
- ✗ Compliance with the permitted temperatures in accordance with EN 60079-0.
- ✗ Make sure the device is used according to its designated use
- ✗ Make sure the operating handle can be reset.



10.2 Cleaning

- ✗ Clean with a cloth, brush, vacuum cleaner or similar items.
- ✗ When cleaning with a damp cloth, use water or mild, non-abrasive, non-scratching cleaning agents.
- ✗ Never use aggressive cleaning agents or solvents.

11 Accessories and Spare Parts

WARNING

Use only original spare parts as well as original accessories made by R. STAHL Schaltgeräte GmbH.

Designation	Illustration	Description	Order number	Weight kg
Jumper	 04951E00	for undervoltage trip, length: 100 mm	8527005870	0,001
	 04951E00	for undervoltage trip, length: 400 mm	8527006870	0,019
Cylinder lock	 05445E00	for locking the terminal if the device is switched off	3756060	0,015

12 Type Examination Certificate (Page 1)



Translation

EC-Type Examination Certificate

- (1)
- (2) **- Directive 94/9/EC -**
Equipment and protective systems intended for use
in potentially explosive atmospheres
- (3) **DMT 02 ATEX E 026**
- (4) **Equipment: Motor protection circuit breaker Type 8527/2.-.-.-.**
- (5) **Manufacturer: R. STAHL Schaltgeräte GmbH**
- (6) **Address: D 74638 Waldenburg (Württ.)**
- (7) The design and construction of this equipment and any acceptable variation thereto are specified in the schedule to this type examination certificate.
- (8) The certification body of Deutsche Montan Technologie GmbH, notified body no. 0158 in accordance with Article 9 of the Directive 94/9/EC of the European Parliament and the Council of 23 March 1994, certifies that this equipment has been found to comply with the Essential Health and Safety Requirements relating to the design and construction of equipment and protective systems intended for use in potentially explosive atmospheres, given in Annex II to the Directive.
The examination and test results are recorded in the test and assessment report BVS PP 02.2020 EC. The Essential Health and Safety Requirements for the integrated safety devices are confirmed according to the EC-Type Examination Certificate PTB 01 ATEX 3307, as of 21. march 2002:
- (9) The Essential Health and Safety Requirements are assured by compliance with:
EN 50014:1997+A1-A2 General requirements
EN 50018:2000 Flameproof enclosure
EN 50019:2000 Increased safety
and the standards according to the EC-Type Examination Certificate PTB 01 ATEX 3307
EN 60947-1, EN 60947-4-1, EN 60947-5-1, EN 60947-2 and EN60079-14
- (10) If the sign "X" is placed after the certificate number, it indicates that the equipment is subject to special conditions for safe use specified in the schedule to this certificate.
- (11) This EC-Type Examination Certificate relates only to the design, examination and tests of the specified equipment in accordance to Directive 94/9/EC.
Further requirements of the Directive apply to the manufacturing process and supply of this equipment. These are not covered by this certificate
- (12) The marking of the equipment shall include the following:

II 2G EEx ed IIC T4/T5/T6

Deutsche Montan Technologie GmbH

Essen, dated 29. April 2002

Signed: Jockers

Signed: Eickhoff

DMT-Certification Body

Head of Special Services Unit

page 1 of 4 to DMT 02 ATEX E 026
This certificate may only be reproduced in its entirety and without change
Am Technologiepark 1, 45307 Essen, Telefon (0201)172-1416, Telefax (0201)172-1716



13 Declaration of Conformity

EG-Konformitätserklärung
EC-Declaration Of Conformity
CE-Déclaration De Conformité

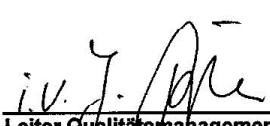

DMT 02 ATEX E026

<p>Wir (we; nous)</p> <p>R. STAHL Schaltgeräte GmbH, Am Bahnhof 30, D-74638 Waldenburg</p> <p>erklären in alleiniger Verantwortung, daß das Produkt Leistungsschalter für Motorschutz Typ 8527/2.-...-...</p> <p>hereby declare in our sole responsibility, that the product Motor protection circuit breaker Typ 8527/2.-...-...</p> <p>déclarons de notre seule responsabilité, que le produit Disjoncteurs pour moteur Typ 8527/2.-...-...</p> <p>auf das sich diese Erklärung bezieht, mit der/den folgenden Norm(en) oder normativen Dokumenten übereinstimmt</p> <p>which is the subject of this declaration, is in conformity with the following standard(s) or normative documents</p> <p>auquel cette déclaration se rapporte, est conforme aux norme (s) ou aux documents normatifs suivants</p>	
<p>Bestimmungen der Richtlinie terms of the directive prescription de la directive</p>	<p>Titel und/oder Nr. sowie Ausgabedatum der Norm title and/or No. and date of issue of the standard titre et/ou No. ainsi que date d'émission des normes</p>
<p>94/9/EG: Geräte und Schutzsysteme zur bestimmungsgemäßen Verwendung in explosionsgefährdeten Bereichen 94/9/EC: Equipment and protective systems intended for use in potentially explosive atmospheres 94/9/CE: Appareils et systèmes de protection destinés à être utilisés en atmosphères explosibles</p>	<p>EN 50014:1997+A1-A2 EN 50018:2000 EN 50019:2000</p>
<p>89/336/EWG: Elektromagnetische Verträglichkeit 89/336/EEC: Electromagnetic compatibility 89/336/CEE: Compatibilité électromagnétique</p>	<p>EN 60947-1:1999 EN 60947-4-1:2001</p>
<p>Waldenburg, 14.02.2002 Ort und Datum Place and date lieu et date</p>	<p> Leiter Marketing und Entwicklung Head of Marketing and Development Directeur Marketing et Développement</p>
	<p> Leiter Qualitätsmanagement Head of Quality Management Chef du dept assurance de qualité</p>

TXV 03/99 Papier chlorfrei



14 Tripping Characteristic Curves

The tripping characteristic curves refer to a 3-pole load from cold state at an ambient temperature of + 20 °C and any position.

The deviation of the tripping time (from a current three times higher than the rated current) is max. 20 % according to EN 60079-14.

The following tripping characteristic curves show the tripping time depending on the current ratio I_a/I_e .

Legend:

- 1) Multiples of the rated current
- 2) Tripping time
- 3) 2-pole
- 4) 3-pole
- 5) Electromagnetic release

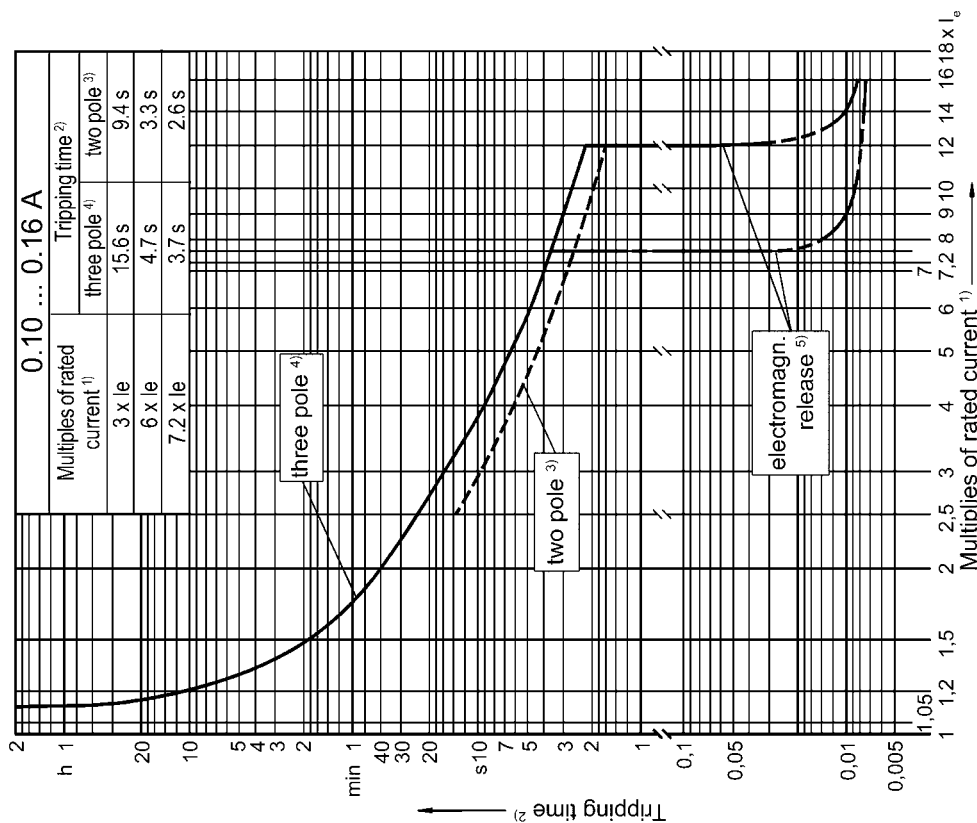

05930E00

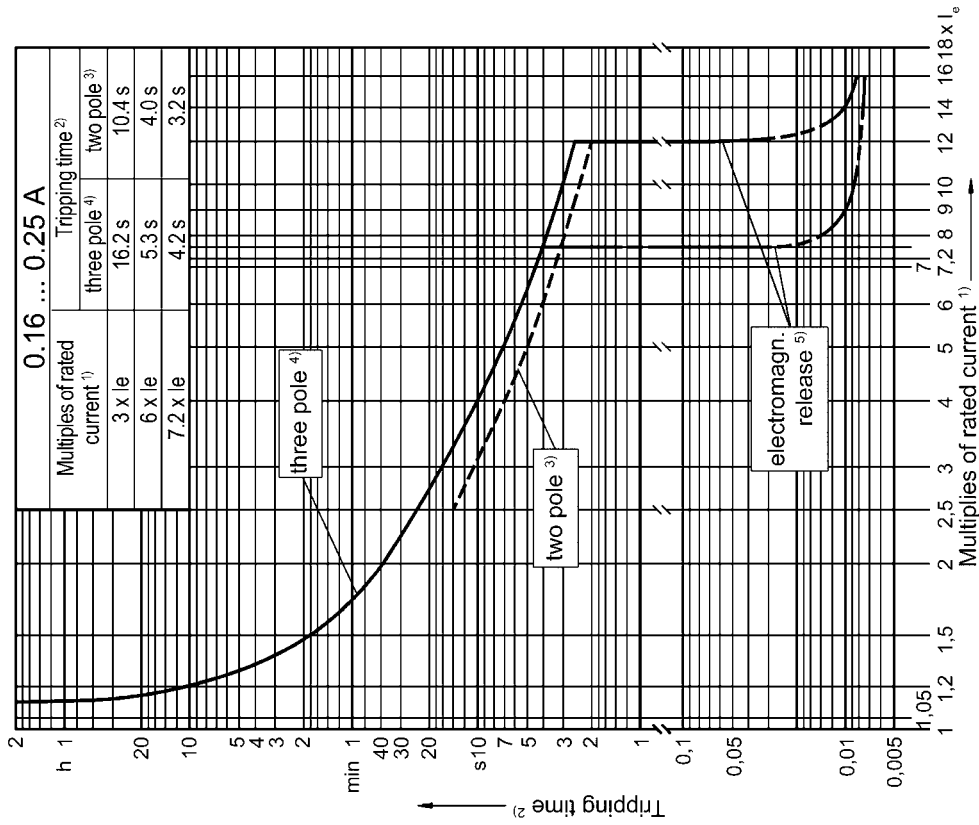

05931E00

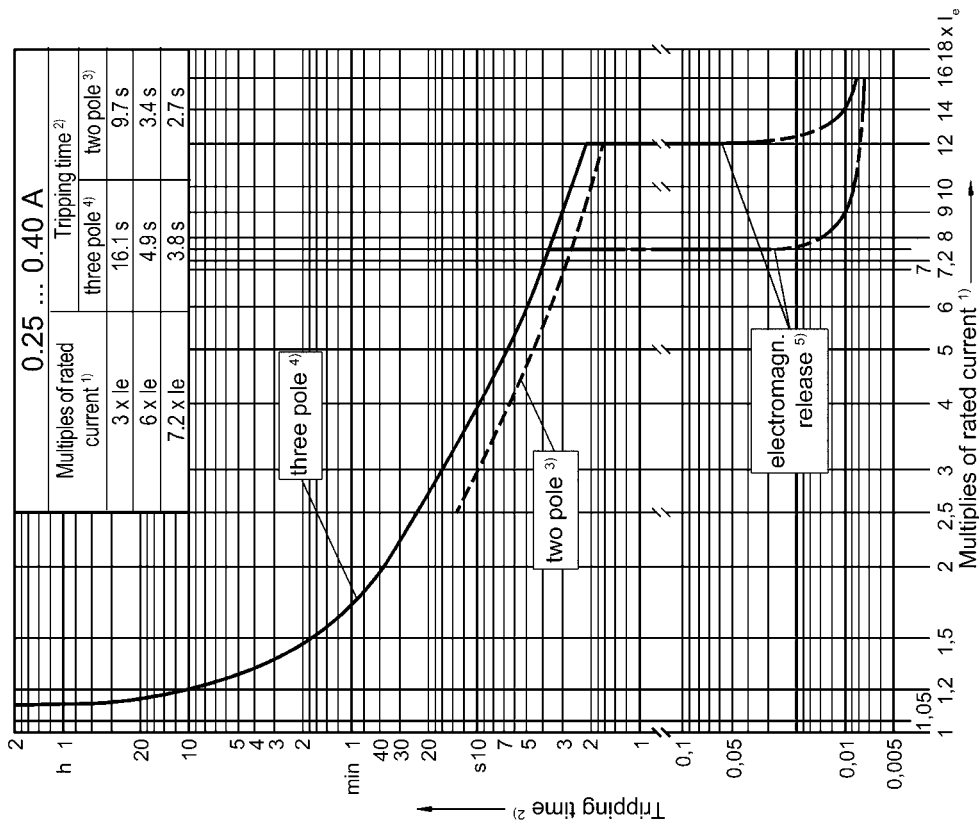

05932E00

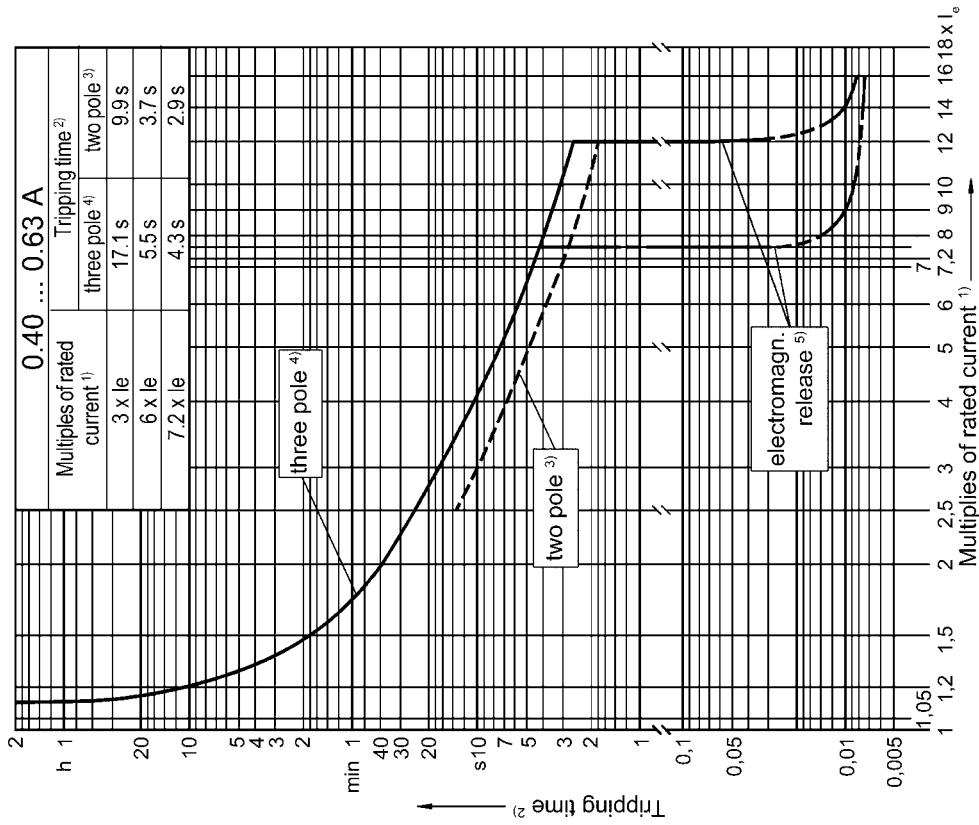

05937E00

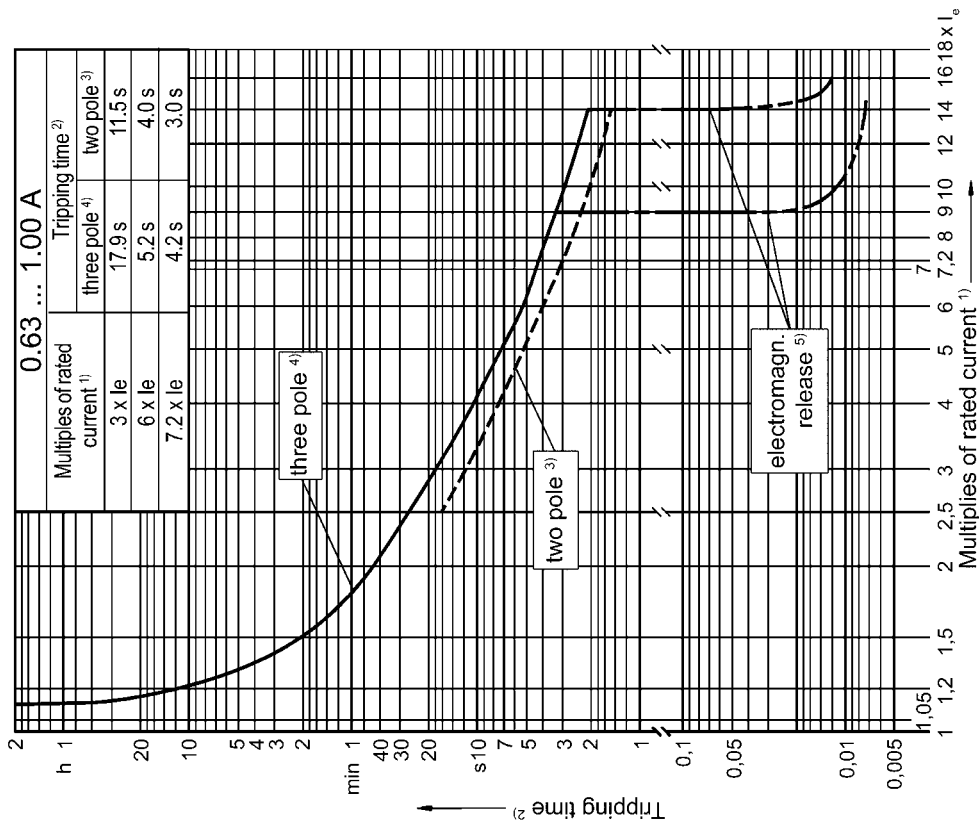

05938E00

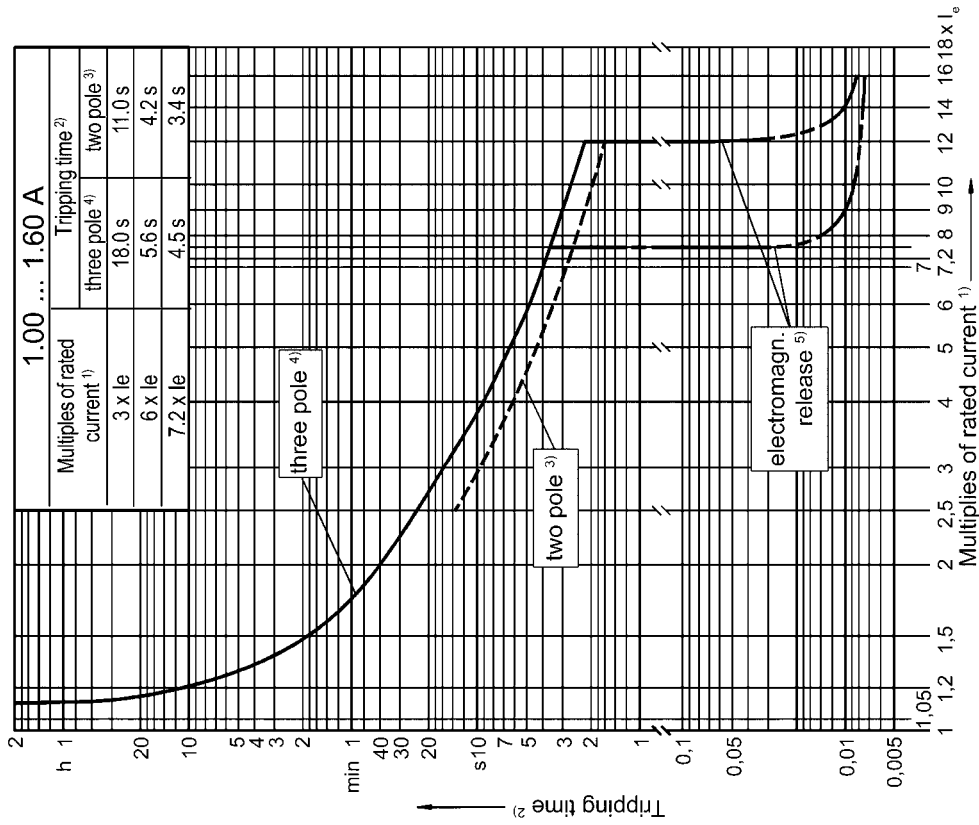

05939E00

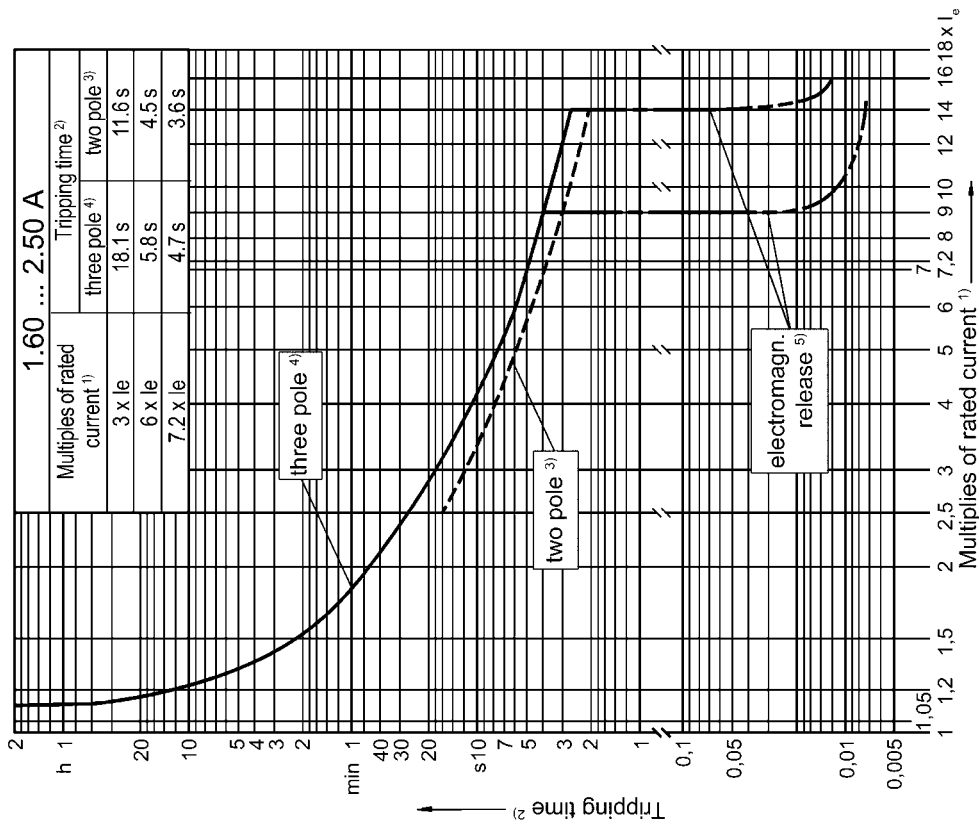

05940E00

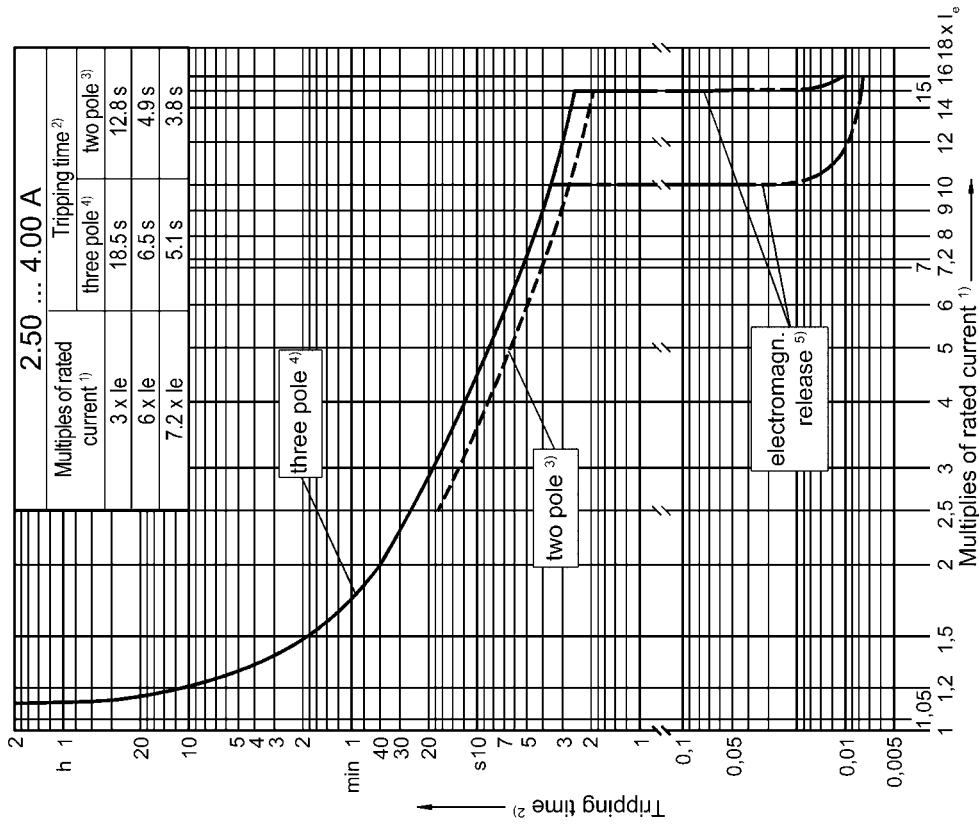

05941E00

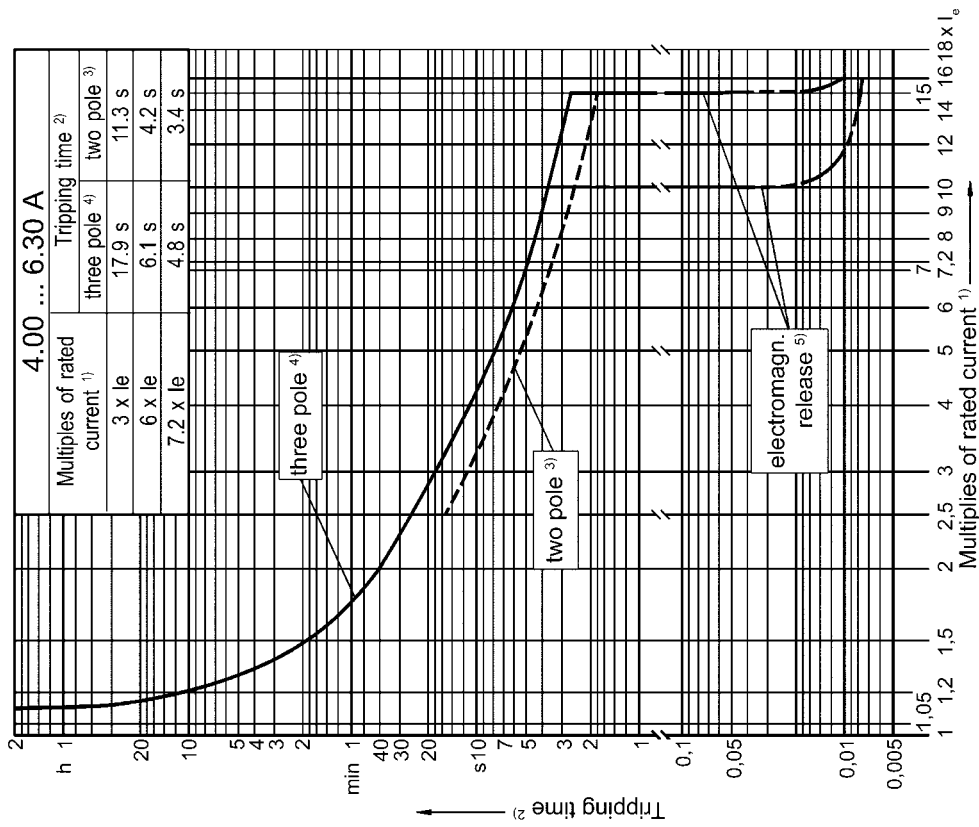

05942E00

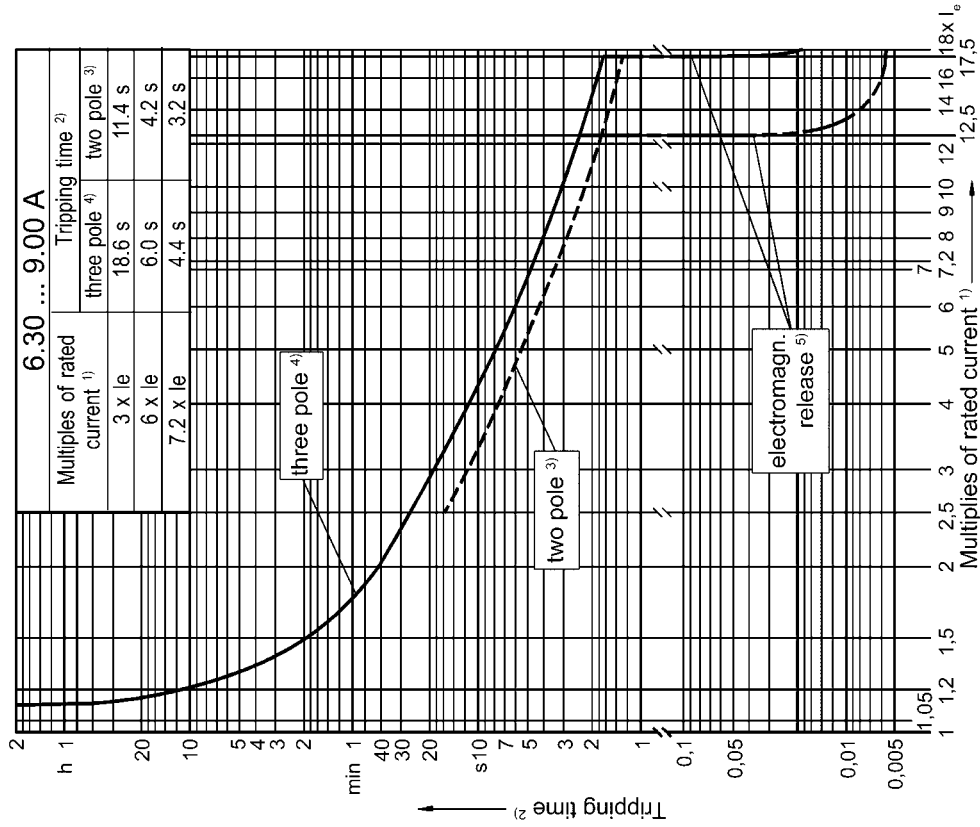

05943E00

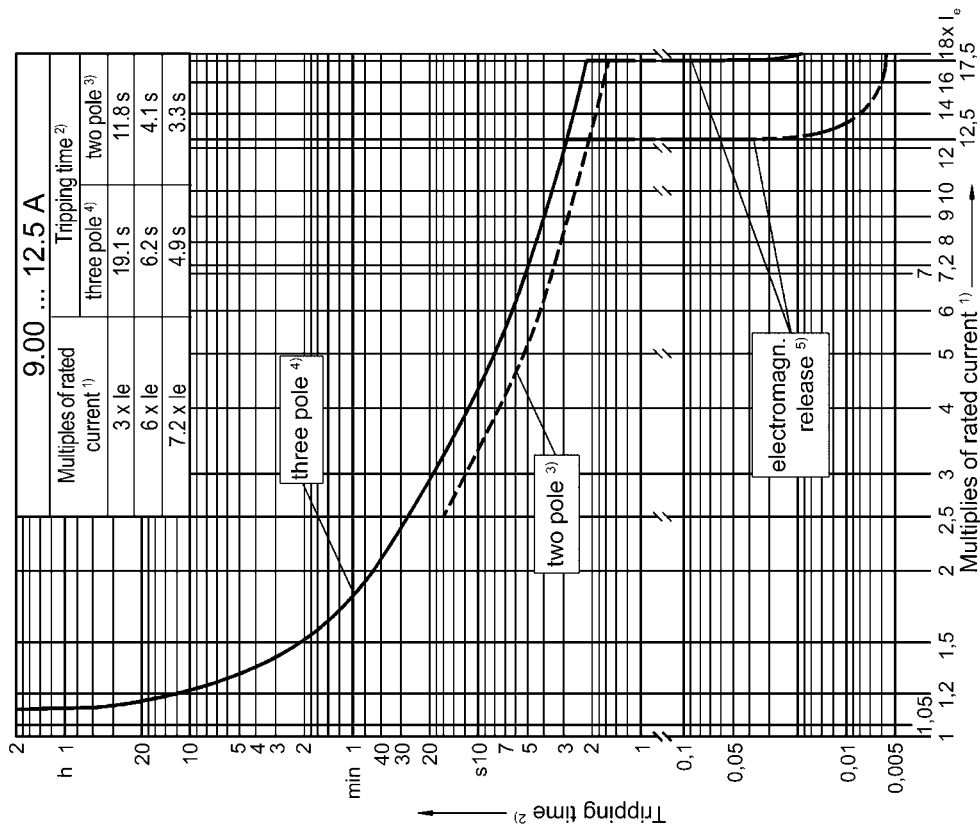

05944E00

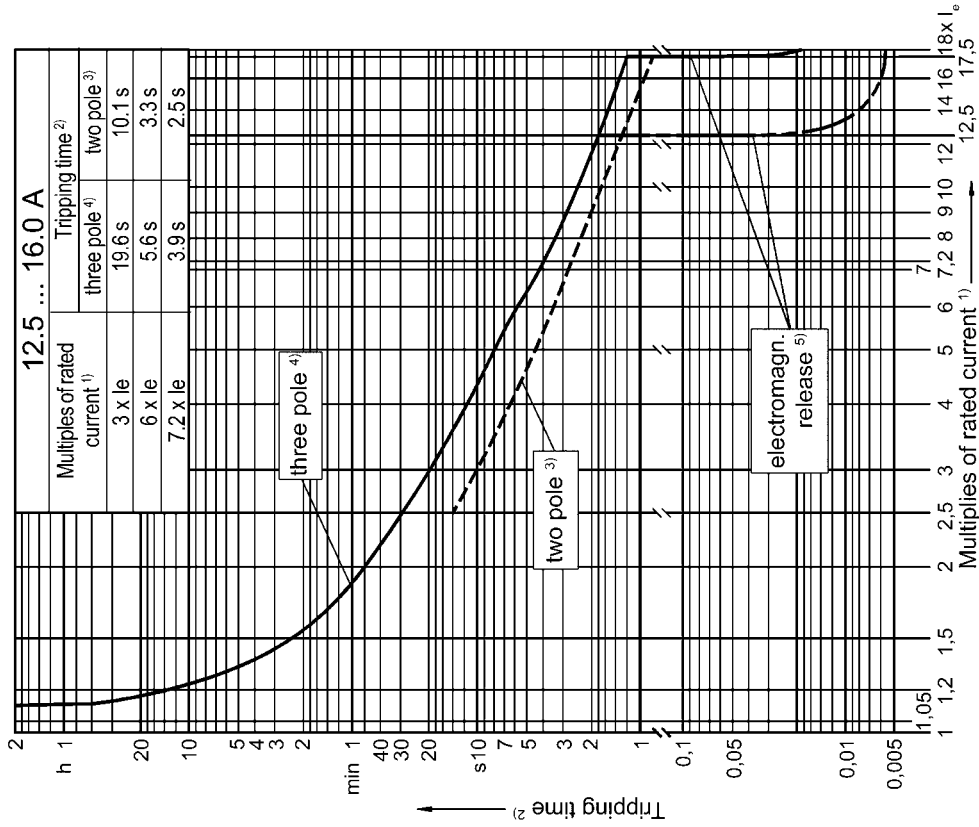

05945E00

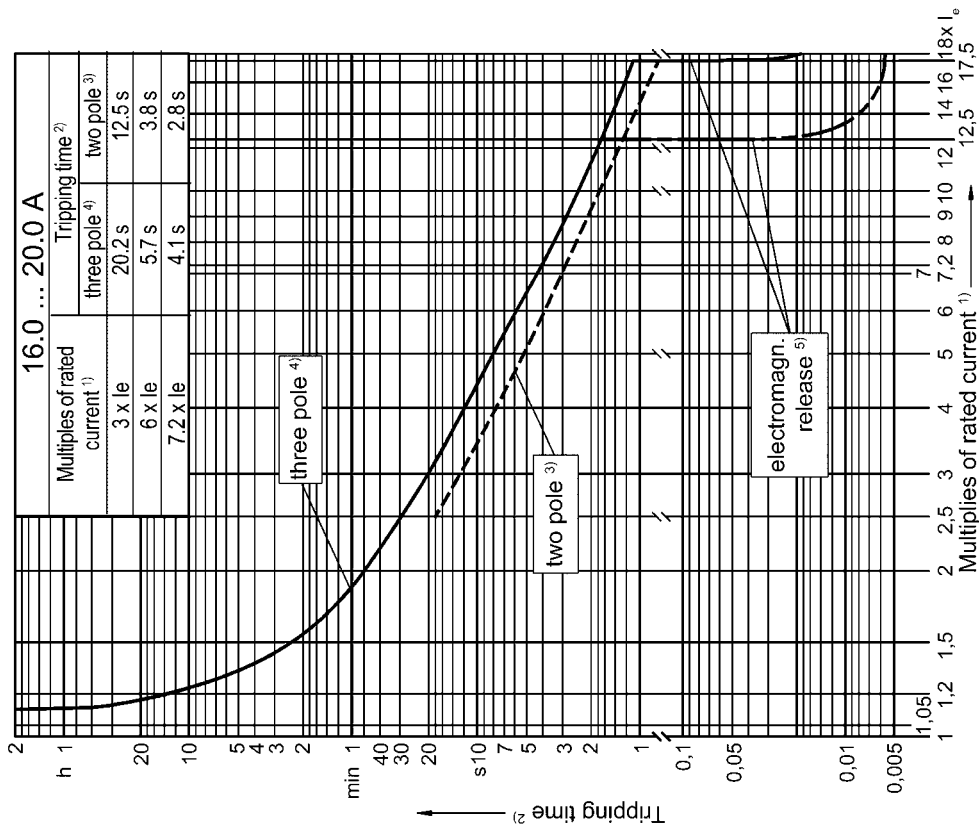

05946E00

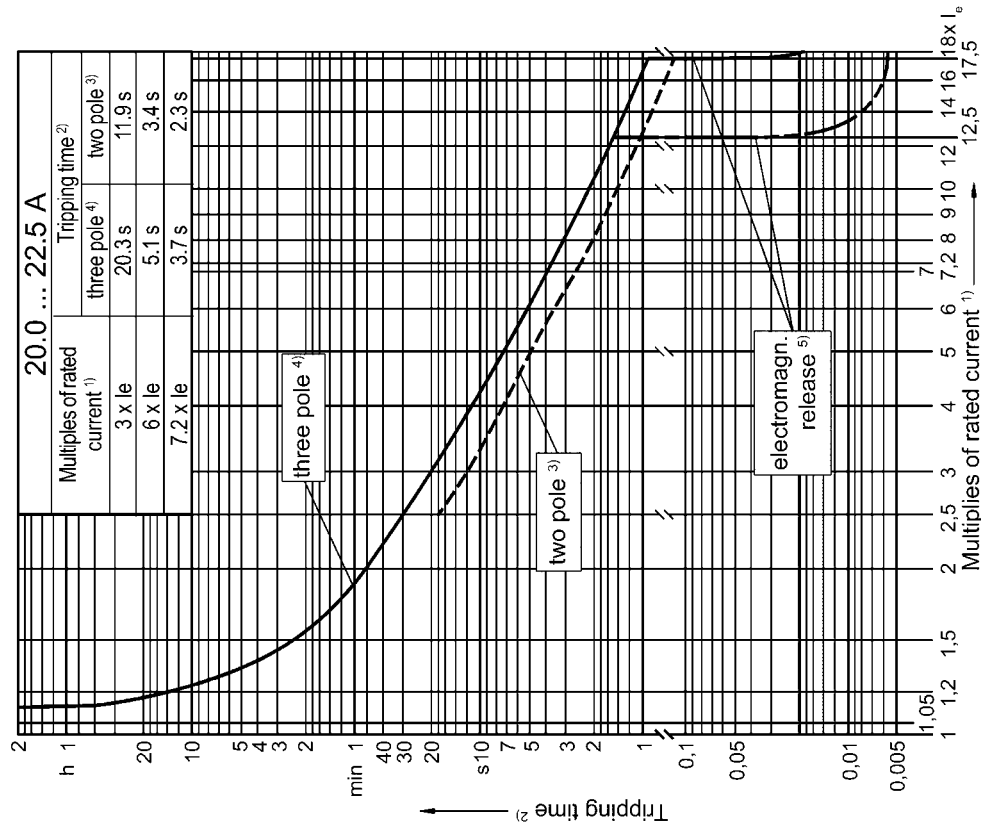

05947E00

☞	<p>Circuit breakers (motor protection circuit breakers) for motors with cage rotor have to be selected in a way that the tripping time at 3-pole load is not longer than the warm-up time t_E given on the type plate of the machine. (The tripping time can be seen in the characteristic curve for the ratio I_A/I_N of the machines to be protected.)</p>
☞	<p>The assignment of tripping times t_A to relative operating currents I_A/I_N has to guarantee the safe switch-off during the warm-up time ($t_A \leq t_E$) and allow a safe run-up of the motor with the trip at operating temperature.</p>
☞	<p>EN 50019 specifies that the warm-up time t_E must not be shorter than 5 seconds.</p>

